

cETLus listed, NEMA TYPE 3R rainproof. All interior components are UL, and ETL certified.
 One piece construction from G90 galvanized steel.
 All surfaces have electrostatic gray powder coated finish.
 120/240 Volts single phase, 125 A.
 Ringless type meter.
 Suitable for campgrounds, RV, and temporary service.
 Commercial Quality receptacles.
 Tin plated copper stabs standard.
 All units factory wired
 All units with standard hub openings, closure plate included.
 All boxes are 9.125" wide.

Please see installation instructions and labels for installation recommendations and guidelines.

Please review the diagrams and sign below.
 All drawings are property of Jamestown Advanced Products. Distribution of drawings without consent of Jamestown Advanced Products is prohibited.

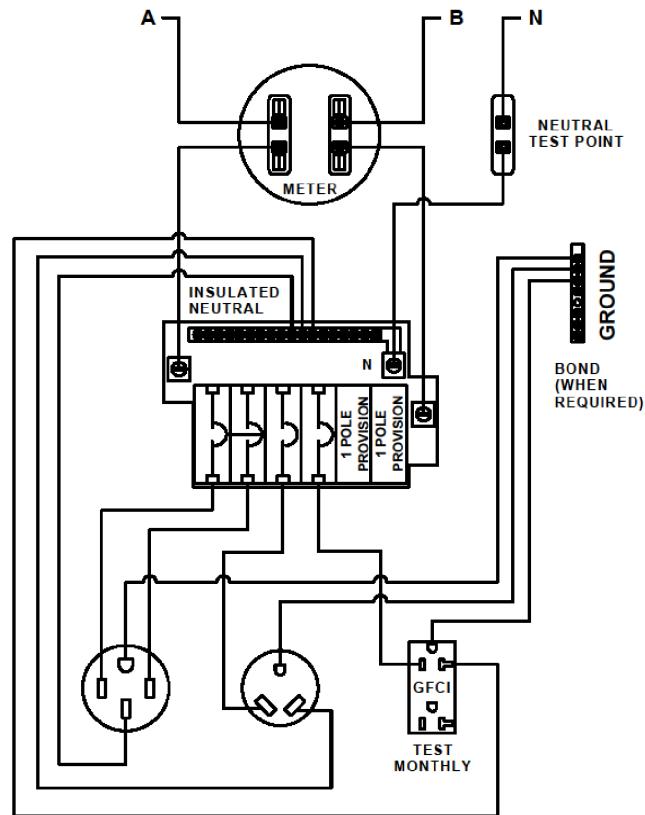

WARNING: MUST BE PERMANENTLY MOUNTED

CUSTOMER APPROVAL :

DATE :



THIS DRAWING, WHICH CONTAINS PROPRIETARY INFORMATION, IS THE PROPERTY OF JAMESTOWN ADVANCED PRODUCTS CORPORATION. IT SHALL NOT BE REPRODUCED IN ANY MANNER NOR DISCLOSED TO THIRD PARTIES WITHOUT WRITTEN PERMISSION OF JAMESTOWN ADVANCED PRODUCTS CORPORATION.

DATE : 3/15/2023

PRODUCT PART NUMBER : PSURFMEG-532-NO

REV. NO. B

PRODUCT DESCRIPTION :

RINGLESS METERED SURFACE MOUNT UNIT

2855 GIRTS ROAD
 JAMESTOWN, NY 14701